



Radar Systems Engineering

Lecture 2

Review of Electromagnetism

Dr. Robert M. O'Donnell
IEEE New Hampshire Section
Guest Lecturer

IEEE New Hampshire Section



Reasons for Review Lecture



- **A number of potential students may not have taken a 3rd year undergraduate course in electromagnetism**
 - **Electrical/Computer Engineering Majors in the Computer Engineering Track**
 - **Computer Science Majors**
 - **Mathematics Majors**
 - **Mechanical Engineering Majors**

- **If this relatively brief review is not sufficient, a formal course in advanced undergraduate course may be required.**



Outline



- **Introduction**
 - **Coulomb's Law**
 - **Gauss's Law**
 - **Biot - Savart Law**
 - **Ampere's Law**
 - **Faraday's Law**
- **Maxwell's Equations**
- **Electromagnetic Waves**



Coulomb's Law



- If two electric charges, q_1 and q_2 , are separated by a distance, r , they experience a force, \vec{F} , given by:

$$\vec{F} = \frac{q_1 q_2 \hat{r}}{4 \pi \epsilon_0 r^2}$$

ϵ_0 = permittivity of free space = $8.85 \times 10^{-12} \text{ C}^2 / (\text{Nm}^2)$

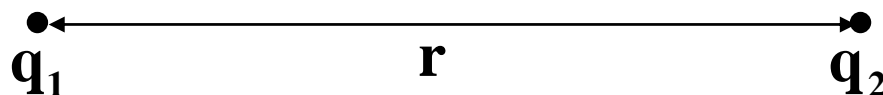

Charles Augustin de Coulomb
(1736-1806)



- Two charges of opposite sign attract; and two charges of the same sign repel each other.
- The magnitude of the electric force is proportional to the magnitude of each of the two charges and inversely proportional to the distance between the two charges
- This electric force is along the line between the two charges



Electric Field



- The **electric field** of a charge q_1 , at P a distance r from the electric charge is defined as:

$$\vec{E}(\mathbf{r}) = \frac{q_1 \hat{\mathbf{r}}}{4\pi\epsilon_0 r^2}$$

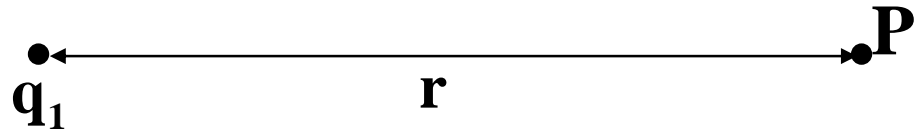



Electric Field



- The **electric field** of a charge q_1 , at a distance r from the electric charge is defined as:

$$\vec{E}(r) = \frac{q_1 \hat{r}}{4\pi\epsilon_0 r^2}$$

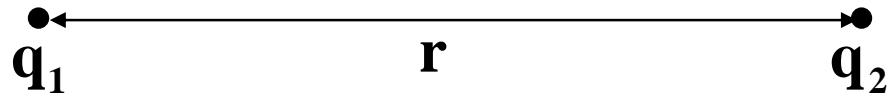

- Remember, that the force on a charge q_2 located a distance r due to q_1 is give by

$$\vec{F} = \frac{q_1 q_2 \hat{r}}{4\pi\epsilon_0 r^2}$$

$$\vec{F} = q \vec{E}$$

- Linear Superposition**

- The total electric field at a point in space is due to a number of point charges is the vector sum of the electric fields of each charge

- Electric field of a point charge**

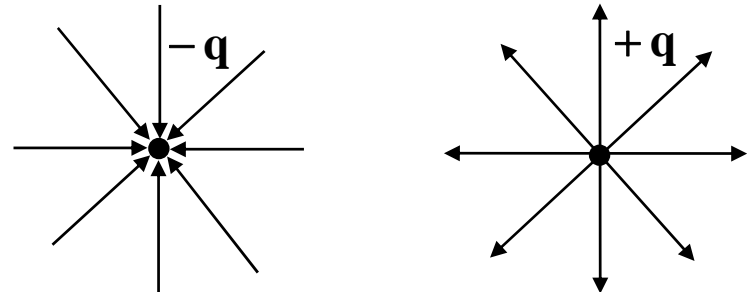



Gauss's Law



- Define: the “Electric Flux Density :

$$\vec{D} = \epsilon_0 \vec{E}$$

- Then, Gauss's Law states that :

$$\oiint \vec{D} \cdot d\vec{S} = Q_{\text{Enclosed}}$$

$$Q_{\text{Enclosed}} = \iiint \rho dV$$

Volume
Charge
Density



Carl Freidrich Gauss
(1777-1855)



- Integrating the Electric Flux Density over a closed surface gives you the charge enclosed by the surface
- Using vector calculus, Gauss's law may be cast in differential form:

$$\nabla \cdot \vec{D} = \rho$$



Biot Savart Law



- Define: \vec{H} = Magnetic Field and \vec{B} = the Magnetic Flux Density

- The Biot-Savart law:

- The differential magnetic field $d\vec{H}$ generated by a steady current flowing through the length $d\vec{l}$ is:

$$d\vec{H} = \left[\frac{I}{4\pi} \right] \left[\frac{d\vec{l} \times \hat{R}}{R^2} \right] \quad (\text{A/m})$$

- where \hat{R} is a unit vector along the line from the current element location to the measurement position of $d\vec{H}$ and R is the distance between the current element location and the measurement position of $d\vec{H}$

- For an ensemble of current elements, the magnetic field is given by:

$$\vec{H} = \left[\frac{I}{4\pi} \right] \int_1 \frac{d\vec{l} \times \hat{R}}{R^2}$$



← Jean-Baptiste Biot
(1774-1862)
Felix Savart
(1791-1841)



Magnetic Flux and the Absence of Magnetic Charges



Magnetic Field of the Earth

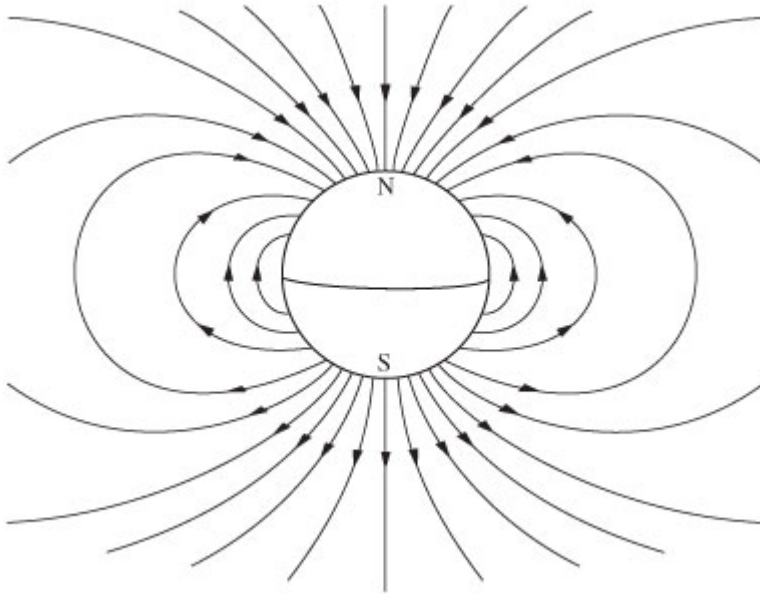

- Law stating that there are no magnetic charges:

$$\oiint \vec{B} \cdot d\vec{S} = 0 \quad \vec{\nabla} \cdot \vec{B} = 0$$

- Integrating the Magnetic Flux Density over a closed surface gives you the magnetic charge enclosed by the surface (zero magnetic charge)

- This is “Gauss’s Law” for magnetism
 - Law of non-existence of magnetic monopoles
 - A number of physicists have searched extensively for magnetic monopoles

Find one and you will get a Nobel Prize

- Magnetic field lines always form closed continuous paths, otherwise magnetic sources (charges) would exist



Amperes Law



- Ampere's law (for constant currents):
- If c is a closed contour bounded by the surface S , then

$$\oint_c \vec{H} \cdot d\vec{s} = \iint_S \vec{J} \cdot d\vec{S} = I \quad \nabla \times \vec{H} = \vec{J}$$

- The sign convention of the closed contour is that \vec{I} and \vec{H} obey the “right hand rule”
- The line integral of \vec{H} around a closed path c equals the current moving through that surface bounded by the closed path

Andre-Marie Ampere
(1775-1836)





Faraday's Law



- A changing magnetic field induces an electric field.

$$\oint_c \vec{E} \cdot d\vec{s} = - \iint_s \frac{\partial \vec{B}}{\partial t} \cdot d\vec{S} \qquad \vec{\nabla} \times \vec{E} = - \frac{\partial \vec{B}}{\partial t}$$

- Induced electric fields are determined by:

$$- \frac{\partial \vec{B}}{\partial t}$$

- Magnetostatic fields are determined by :

$$\mu_0 \vec{J}$$

Michael Faraday
(1791-1867)





Outline



- Introduction
- • **Maxwell's Equations**
 - Displacement Current
 - Continuity Equation
 - Boundary Equations
- Electromagnetic Waves



Electromagnetism (Pre Maxwell)



Gauss's Law $\oiint \vec{D} \cdot d\vec{S} = \iiint \rho dV$

$$\nabla \cdot \vec{D} = \rho$$

Magnetic Charges
Do Not Exist $\oiint \vec{B} \cdot d\vec{S} = 0$

$$\nabla \cdot \vec{B} = 0$$

Faradays's Law $\oint \vec{E} \cdot d\vec{s} = - \iint \frac{\partial \vec{B}}{\partial t} \cdot d\vec{S}$

$$\vec{\nabla} \times \vec{E} = - \frac{\partial \vec{B}}{\partial t}$$

Ampere's Law $\oint \vec{H} \cdot d\vec{s} = \vec{J} \cdot d\vec{S}$

$$\vec{\nabla} \times \vec{H} = \frac{\partial \vec{D}}{\partial t} + \vec{J}$$

$$\vec{D} = \epsilon \vec{E} \quad \vec{B} = \mu \vec{H}$$

- **Surprise! These formulae are inconsistent!**



The “Pre-Maxwell Equations” Inconsistency



- Inconsistency comes about because a well known property of vectors:

$$\vec{\nabla} \cdot (\vec{\nabla} \times \vec{A}) = 0$$

- Apply this to Faraday’s law

$$\vec{\nabla} \cdot (\vec{\nabla} \times \vec{E}) = \vec{\nabla} \cdot \left(\frac{-\partial \vec{B}}{\partial t} \right) = -\frac{\partial}{\partial t} (\vec{\nabla} \cdot \vec{B})$$

- The left side is equal to 0, because of the above noted property of vectors
- The right side is 0, because $\vec{\nabla} \cdot \vec{B} = 0$
- If you do the same operation to Ampere’s lawTrouble..



“How Displacement Current Came to Be”



$$\vec{\nabla} \cdot (\vec{\nabla} \times \vec{H}) = \frac{\vec{\nabla} \cdot \vec{J}}{\mu_0}$$

- The left side is 0; but the right side is not, generally 0
- If one applies Gauss's law and the continuity equation:

$$\vec{\nabla} \cdot \vec{J} + \frac{\partial \rho}{\partial t} = 0$$

- The above equation become:

$$\vec{\nabla} \cdot \vec{J} = -\frac{\partial \rho}{\partial t} = -\frac{\partial}{\partial t} (\epsilon_0 \vec{\nabla} \cdot \vec{E}) = -\nabla \cdot \left(\epsilon_0 \frac{\partial \vec{E}}{\partial t} \right)$$

- So Maxwell's Equations become consistent, if we rewrite Ampere's law as:

$$\vec{\nabla} \times \vec{H} = \vec{J} + \frac{\partial \vec{D}}{\partial t} \leftarrow \text{Displacement current}$$

- A changing electric field induces an magnetic field



Review - Electromagnetism

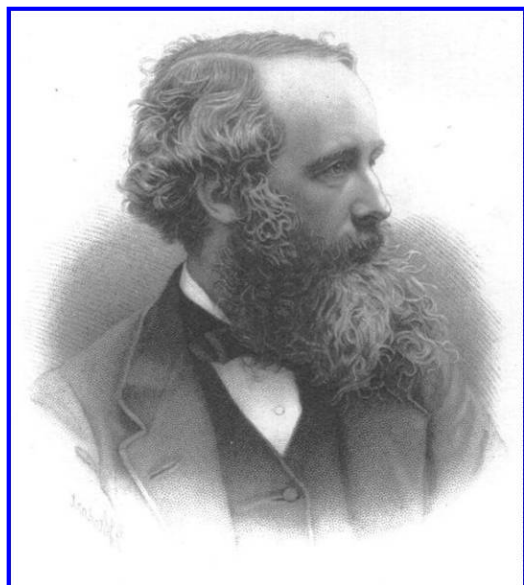

James Clerk Maxwell

Maxwell's Equations

Integral Form

$$\oiint \vec{D} \cdot d\vec{S} = \iiint \rho dV$$

$$\oiint \vec{B} \cdot d\vec{S} = 0$$

$$\oint \vec{E} \cdot d\vec{s} = -\iint \frac{\partial \vec{B}}{\partial t} \cdot d\vec{S}$$

$$\oint \vec{H} \cdot d\vec{s} = \iint \left(\frac{\partial \vec{D}}{\partial t} + \vec{J} \right) \cdot d\vec{S}$$

$$\vec{D} = \epsilon \vec{E}$$

$$\vec{B} = \mu \vec{H}$$

Differential Form

$$\nabla \cdot \vec{D} = 4\pi\rho$$

$$\nabla \cdot \vec{B} = 0$$

$$\nabla \times \vec{E} = -\frac{\partial \vec{B}}{\partial t}$$

$$\nabla \times \vec{H} = \frac{\partial \vec{D}}{\partial t} + \vec{J}$$

■ Electric Field
■ Magnetic Field

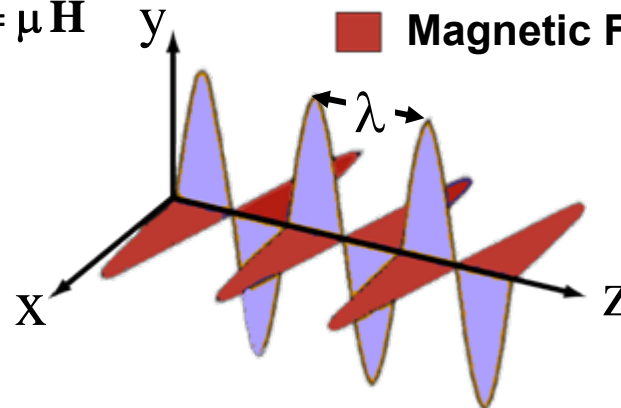

Plane Wave Solution

No Sources

Vacuum

Non-Conducting Medium

$$\vec{E}(\vec{r}, t) = \vec{E}_0 e^{j(\vec{k} \cdot \vec{r} - \omega t)}$$

$$\vec{B}(\vec{r}, t) = \vec{B}_0 e^{j(\vec{k} \cdot \vec{r} - \omega t)}$$



Boundary Equations



D_{n1} is the normal component of \vec{D} at the top of the pillbox

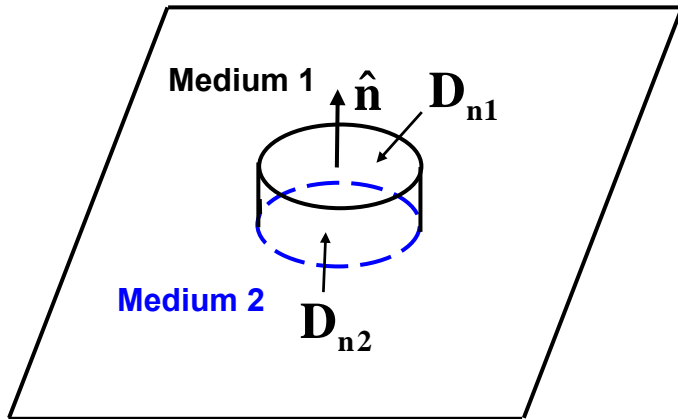

- In the limit, when the side surfaces approach 0, Gauss's law reduces to:

$$\hat{n} \cdot (\vec{D}_1 - \vec{D}_2) = \sigma_s$$

- And from $\oiint \vec{B} \cdot d\vec{S} = 0$

$$\hat{n} \cdot (\vec{B}_1 - \vec{B}_2) = 0$$

- The scalar form of these equations is

$$D_{n1} - D_{n2} = \sigma_s$$

$$B_{n1} - B_{n2} = 0$$

$$\oiint \vec{D} \cdot d\vec{S} = \iiint \rho dV$$



Boundary Equations (continued)



\mathbf{H}_{t1} is the tangential component of $\vec{\mathbf{H}}$ at the top of the pillbox

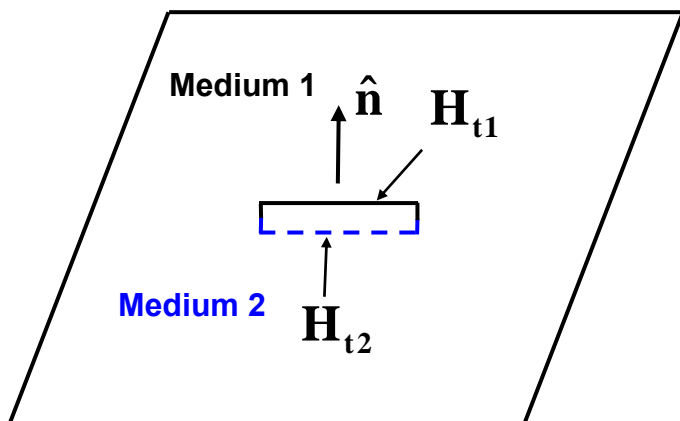

- In the limit, when the sides of the rectangle approach 0, Ampere's law reduces to:

$$\hat{\mathbf{n}} \times (\vec{\mathbf{H}}_1 - \vec{\mathbf{H}}_2) = \vec{\mathbf{J}}_s$$

- And from Faraday's law

$$\hat{\mathbf{n}} \times (\vec{\mathbf{E}}_1 - \vec{\mathbf{E}}_2) = \mathbf{0}$$

- The scalar form of these equations is

$$\mathbf{H}_{t1} - \mathbf{H}_{t2} = |\vec{\mathbf{J}}_s|$$

$$\mathbf{E}_{t1} - \mathbf{E}_{t2} = \mathbf{0}$$

At the Surface of a Perfect Conductor

$$\hat{\mathbf{n}} \times \vec{\mathbf{E}} = \mathbf{0} \quad \hat{\mathbf{n}} \cdot \vec{\mathbf{D}} = \sigma_s$$

$$\hat{\mathbf{n}} \times \vec{\mathbf{H}} = \vec{\mathbf{J}}_s \quad \hat{\mathbf{n}} \cdot \vec{\mathbf{B}} = \mathbf{0}$$



Outline



- Introduction
- Maxwell's Equations
- • **Electromagnetic Waves**
 - How they are generated
 - Free Space Propagation
 - Near Field / Far Field
 - Polarization
 - Propagation
 - Waveguides
 - Coaxial Transmission Lines
 - Miscellaneous Stuff



Radiation of Electromagnetic Waves



- Radiation is created by a time-varying current, or an acceleration (or deceleration) of charge
- Two examples:
 - An oscillating electric dipole
Two electric charges, of opposite sign, whose separation oscillates accordingly:

$$\mathbf{x} = \mathbf{d}_0 \sin \omega t$$

- An oscillating magnetic dipole
A loop of wire, which is driven by an oscillating current of the form:
- $$\mathbf{I}(t) = \mathbf{I}_0 \sin \omega t$$
- Either of these two methods are examples of ways to generate electromagnetic waves



Radiation from an Oscillating Electric Dipole

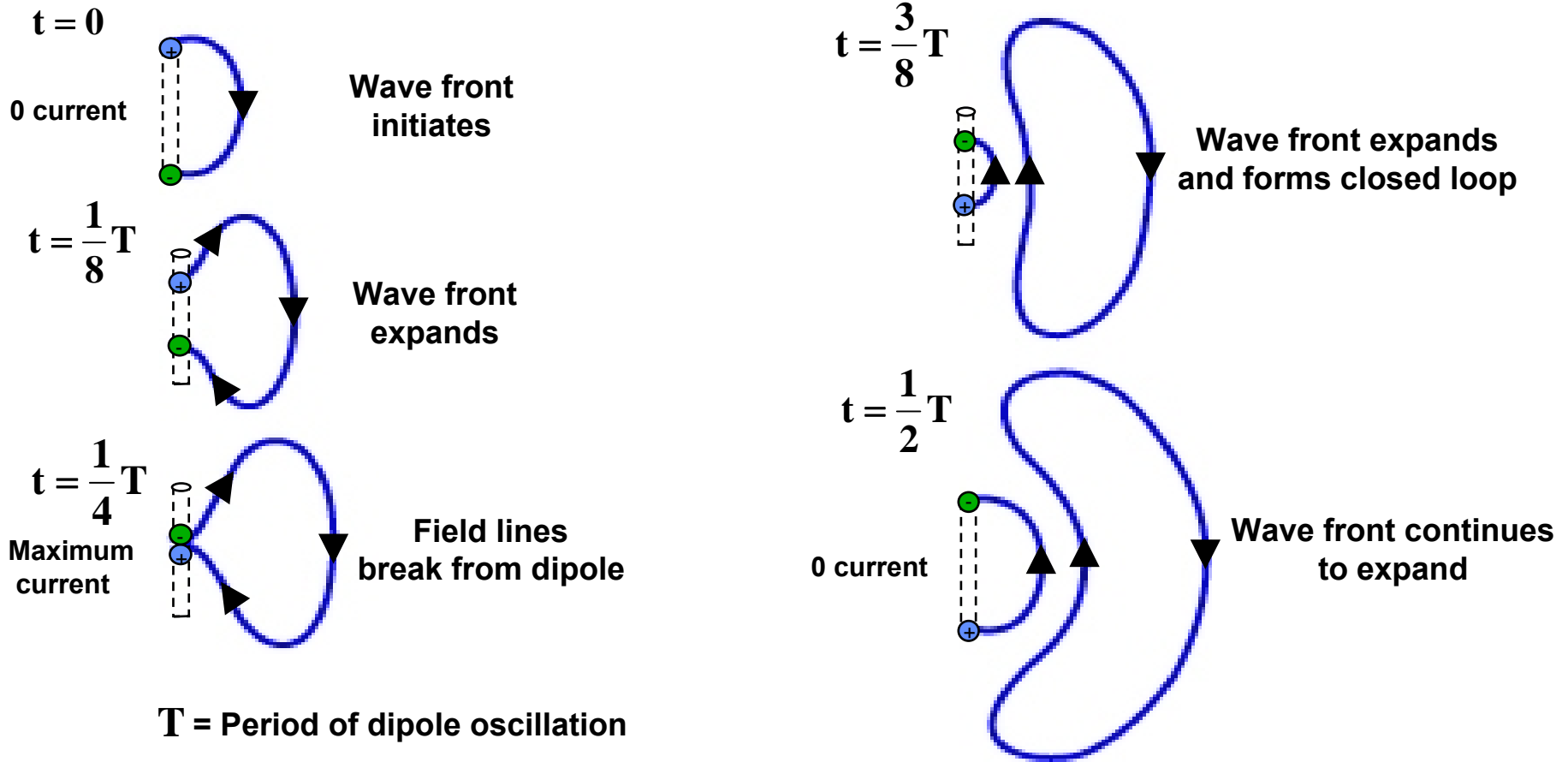
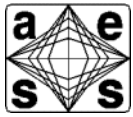

Illustration of propagation and detachment of electric field lines from the dipole
Two charges in simple harmonic motion



MATLAB Movies for Visualization of Antenna Radiation with Time



- **Generated via Finite Difference Time Domain (FDTD) solution**
 - We will study this method in a later lecture
- **Two Cases:**
 - Single dipole / harmonic source
 - Two dipoles / harmonic sources

**Electric charges are needed to create an electromagnetic wave,
but are not required to sustain it**



Dipole Radiation in Free Space

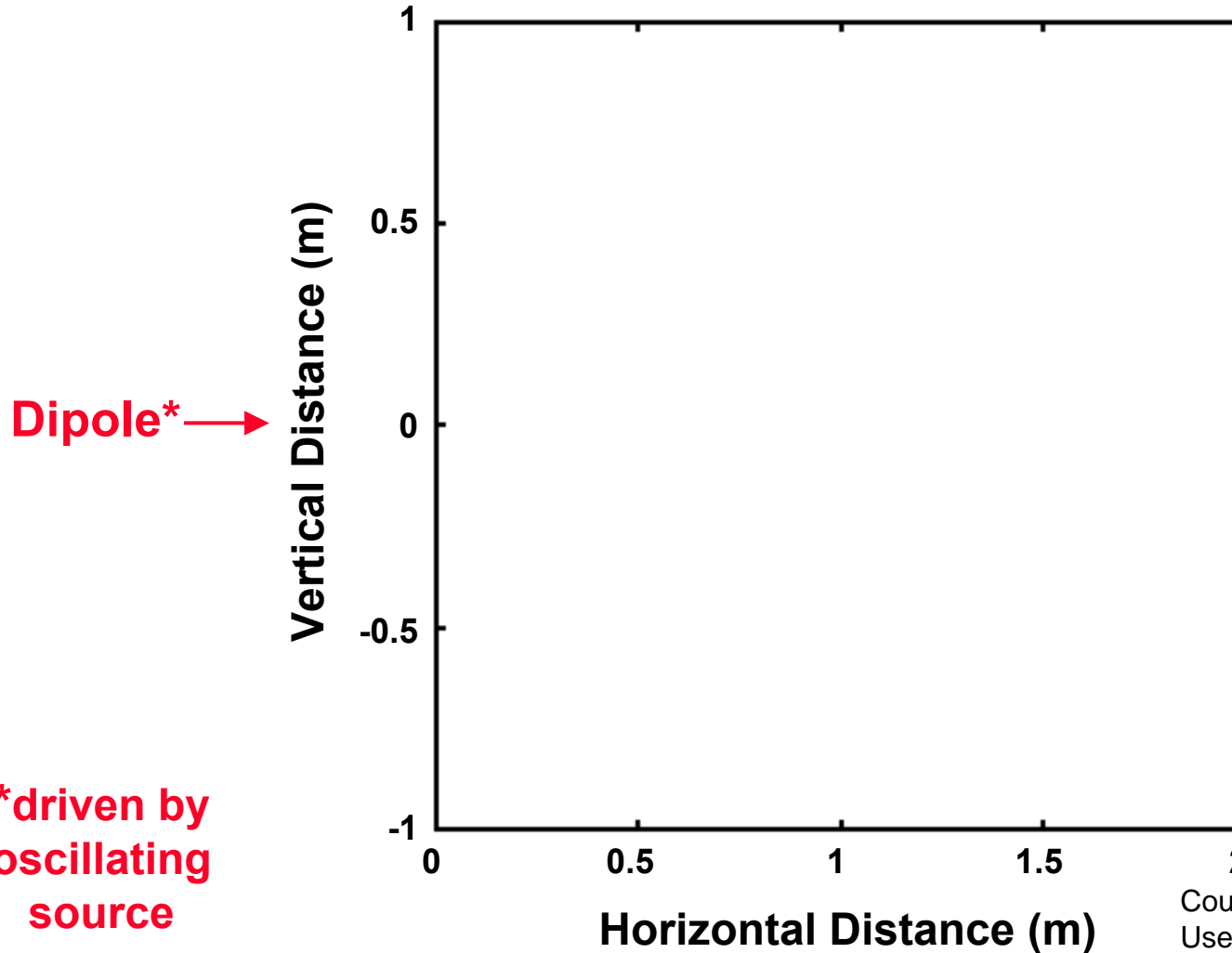
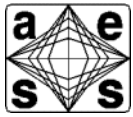

Courtesy of MIT Lincoln Laboratory
Used with Permission



Two Antennas Radiating



Dipole
1*



Dipole
2*



*driven by
oscillating
sources
(in phase)

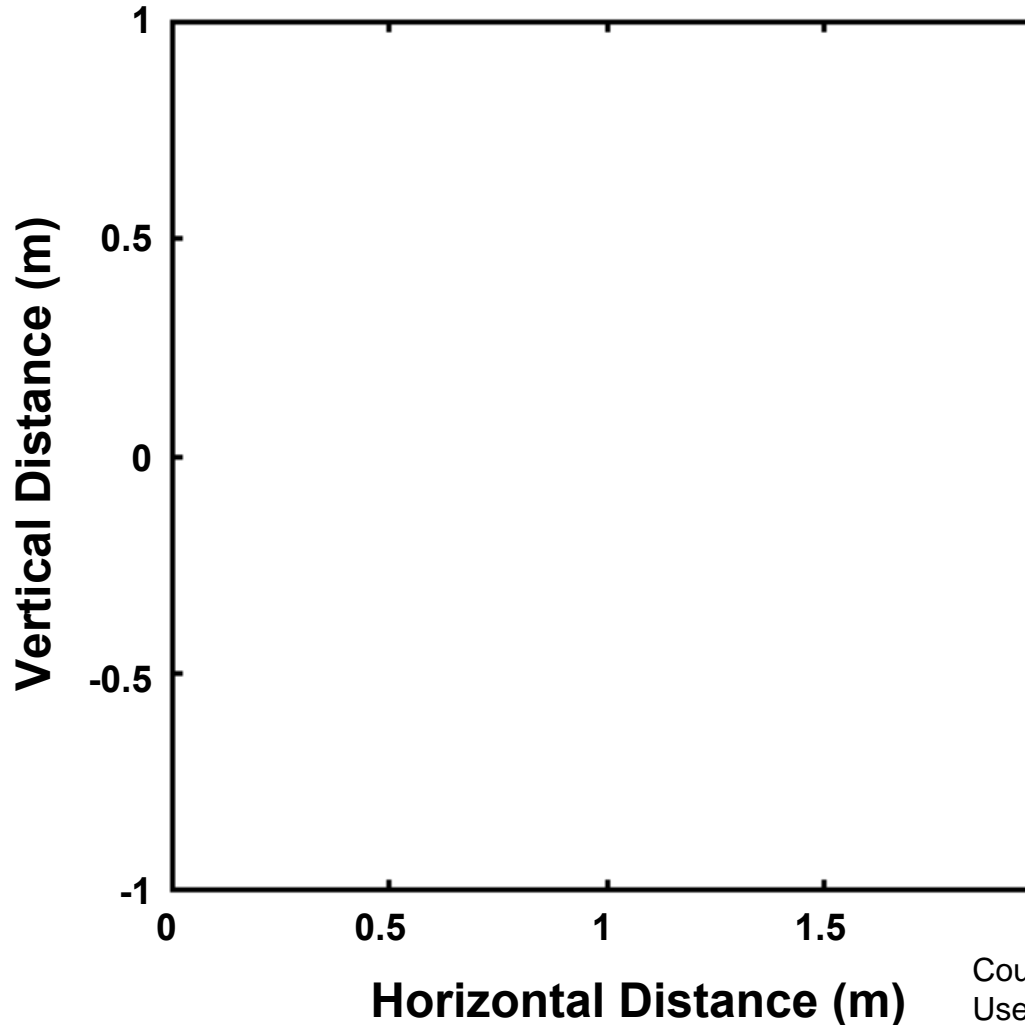

Courtesy of MIT Lincoln Laboratory
Used with Permission



Electromagnetic Waves



THE ELECTROMAGNETIC SPECTRUM

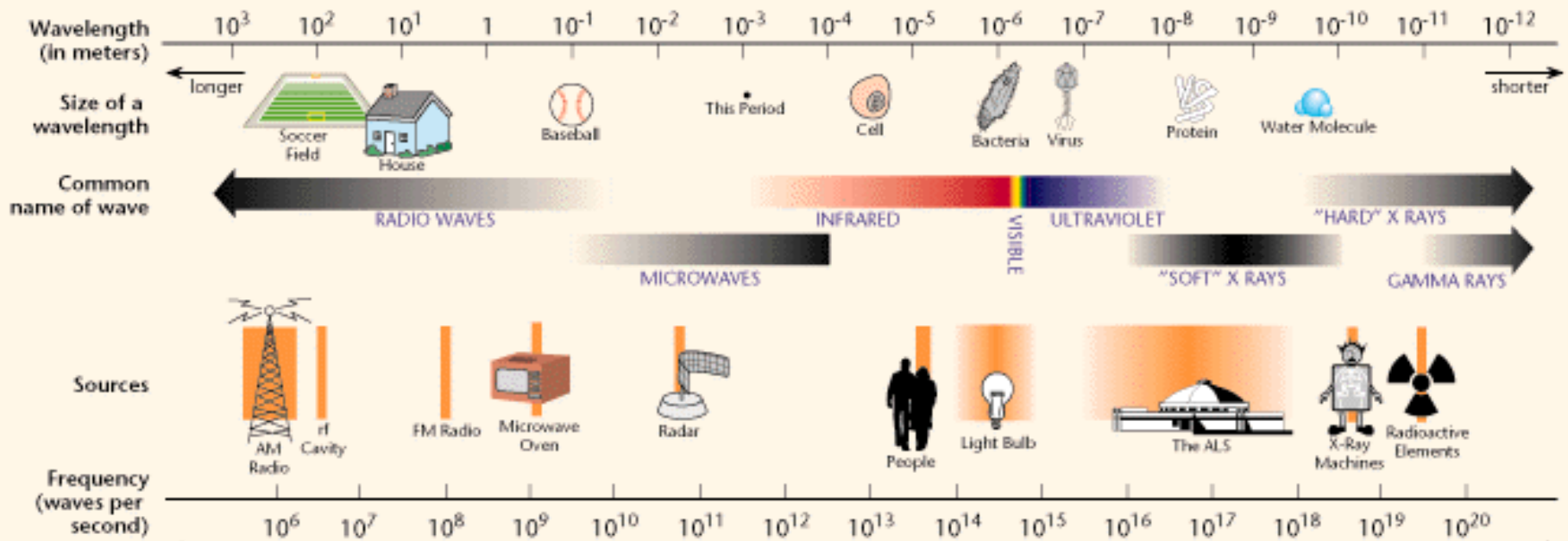

Courtesy Berkeley National Laboratory

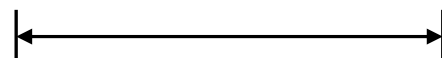

Radar Frequencies



Why Microwaves for Radar

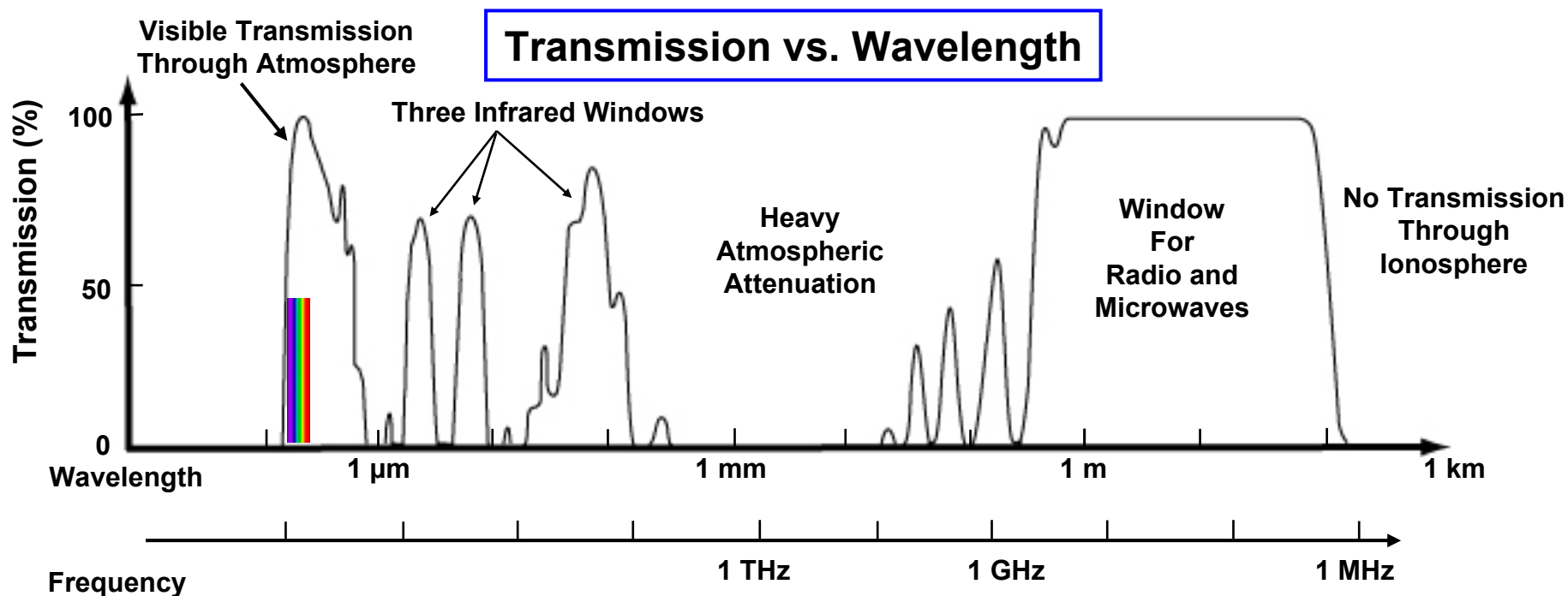
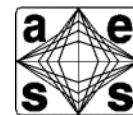

- The microwave region of the electromagnetic spectrum (~3 MHz to ~10 GHz) is bounded by:
- One region (> 10 GHz) with very heavy attenuation by the gaseous components of the atmosphere (except for windows at 35 & 95 GHz)
 - The other region (< 3 MHz), whose frequency implies antennas too large for most practical applications



Electromagnetic Wave Properties and Generation / Calculation

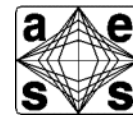

- A **radiated** electromagnetic wave consists of electric and magnetic fields which *jointly* satisfy Maxwell's Equations
- EM wave is derived by integrating source currents on antenna / target
 - Electric currents on metal
 - Magnetic currents on apertures (transverse electric fields)
- Source currents can be modeled and calculated
 - Distributions are often assumed for simple geometries
 - Numerical techniques are used for more rigorous solutions (e.g. Method of Moments, Finite Difference-Time Domain Methods)

Electric Current on Wire Dipole

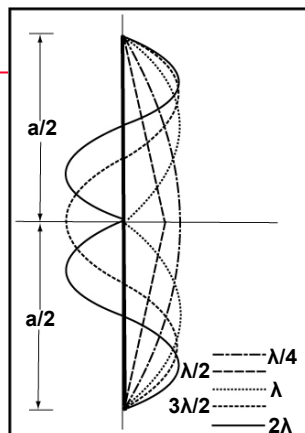

Electric Field Distribution (~ Magnetic Current) in Slot

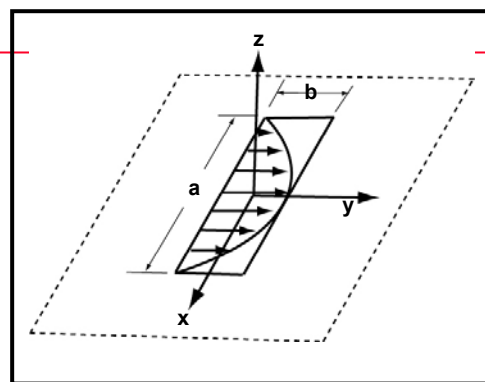



Antenna and Radar Cross Section Analyses Use “Phasor Representation”



Harmonic Time Variation is assumed : $e^{j\omega t}$

$$\underbrace{\vec{E}(\mathbf{x}, \mathbf{y}, \mathbf{z}; t)}_{\substack{\uparrow \\ \text{Instantaneous} \\ \text{Electric Field}}} = \text{Real} \left[\underbrace{\tilde{E}(\mathbf{x}, \mathbf{y}, \mathbf{z})}_{\substack{\uparrow \\ \text{Phasor}}} e^{j\omega t} \right]$$

Calculate Phasor : $\tilde{E}(\mathbf{x}, \mathbf{y}, \mathbf{z}) = \hat{e} \left| \tilde{E}(\mathbf{x}, \mathbf{y}, \mathbf{z}) \right| e^{j\alpha}$

Instantaneous Harmonic Field is : $\vec{E}(\mathbf{x}, \mathbf{y}, \mathbf{z}; t) = \hat{e} \left| \tilde{E}(\mathbf{x}, \mathbf{y}, \mathbf{z}) \right| \cos(\omega t + \alpha)$

Any Time Variation can be Expressed as a Superposition of Harmonic Solutions by Fourier Analysis



Field Regions



Reactive Near-Field Region

$$R < 0.62\sqrt{D^3/\lambda}$$

- Energy is stored in vicinity of antenna
- Near-field antenna issues
 - Input impedance
 - Mutual coupling

Far-field (Fraunhofer) Region

$$R > 2D^2/\lambda$$

- All power is radiated out
- Radiated wave is a plane wave
- Far-field EM wave properties
 - Polarization
 - Antenna Gain (Directivity)
 - Antenna Pattern
 - Target Radar Cross Section (RCS)

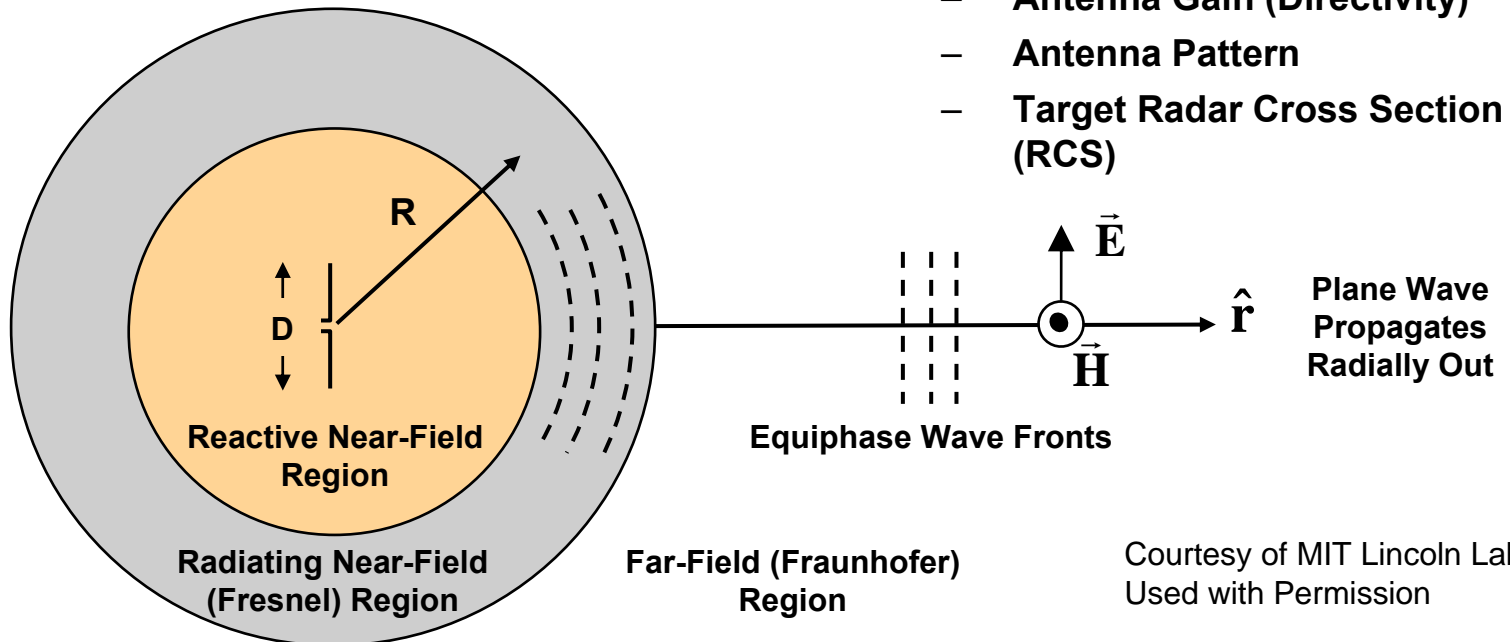

Courtesy of MIT Lincoln Laboratory
Used with Permission



Far-Field EM Wave Properties



- In the far-field, a spherical wave can be approximated by a plane wave
- There are no radial field components in the far field
- The electric and magnetic fields are given by:

$$\vec{E}^{\text{ff}}(\mathbf{r}, \theta, \phi) \cong \vec{E}^{\circ}(\theta, \phi) \frac{e^{-jkr}}{r}$$
$$\vec{H}^{\text{ff}}(\mathbf{r}, \theta, \phi) \cong \vec{H}^{\circ}(\theta, \phi) \frac{e^{-jkr}}{r} = \frac{1}{\eta} \hat{\mathbf{r}} \times \vec{E}^{\text{ff}}$$

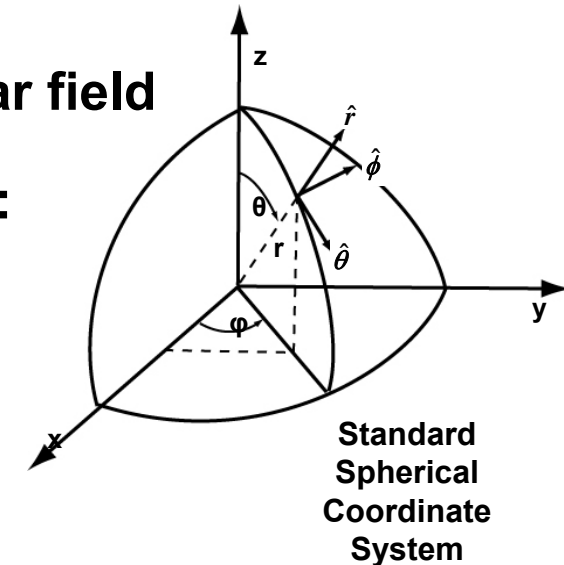

where $\eta \equiv \sqrt{\frac{\mu_0}{\epsilon_0}} = 377 \Omega$ is the intrinsic impedance of free space
 $\mathbf{k} = 2\pi/\lambda$ is the wave propagation constant

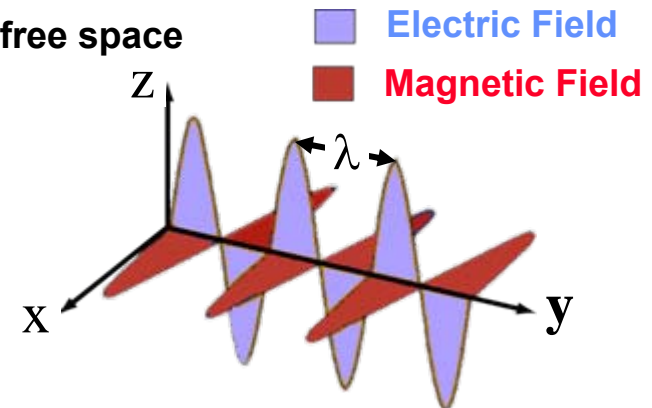



Polarization of Electromagnetic Wave



- Defined by behavior of the electric field vector as it propagates in time *as observed along the direction of radiation*
- Circular used for weather mitigation
- Horizontal used in long range air search to obtain reinforcement of direct radiation by ground reflection

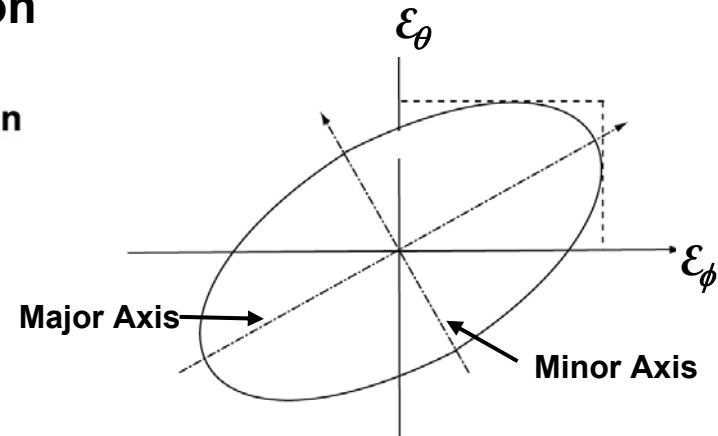
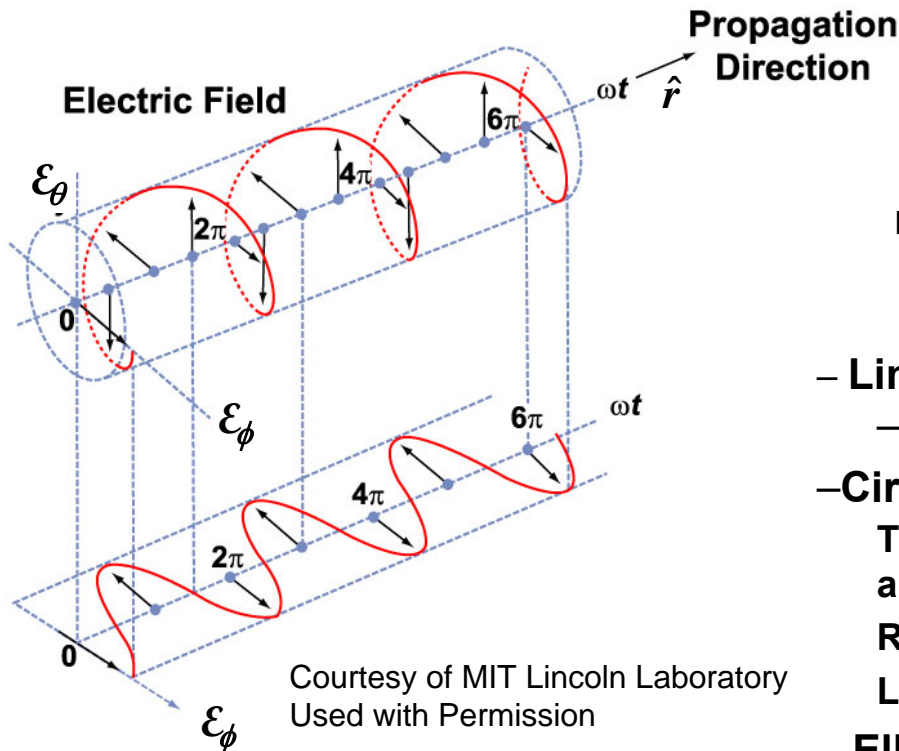

- Linear
 - Vertical or Horizontal
- Circular
 - Two components are equal in amplitude, and separated in phase by 90 deg
 - Right-hand (RHCP) is CW above
 - Left-hand (LHCP) is CCW above
- Elliptical



Polarization

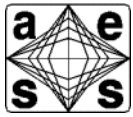

- Defined by behavior of the electric field vector as it propagates in time

Courtesy of MIT Lincoln Laboratory
Used with Permission

Electromagnetic
Wave

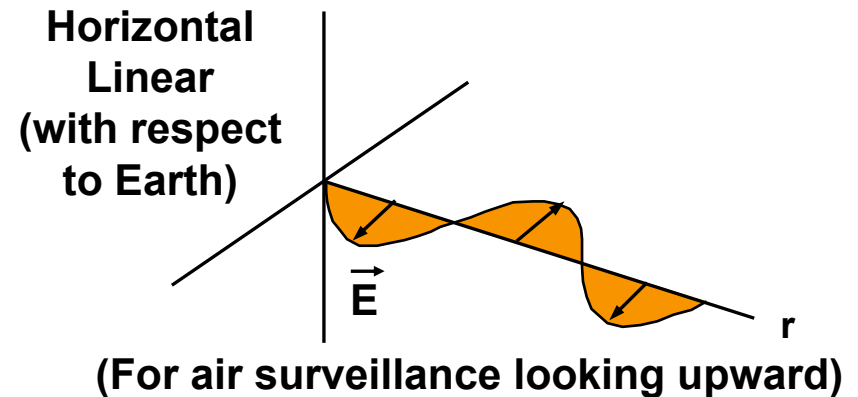
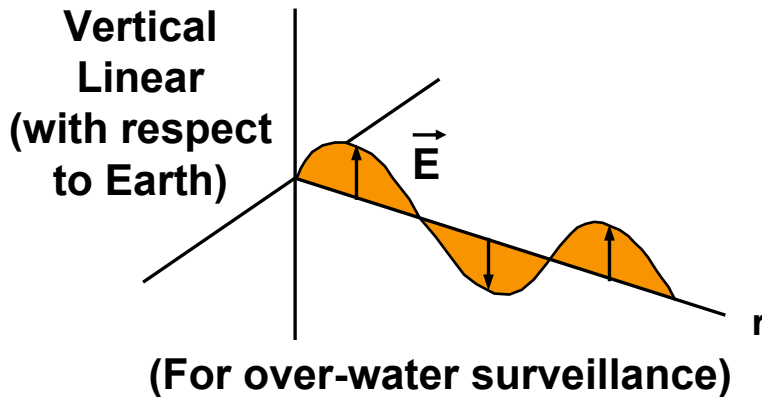
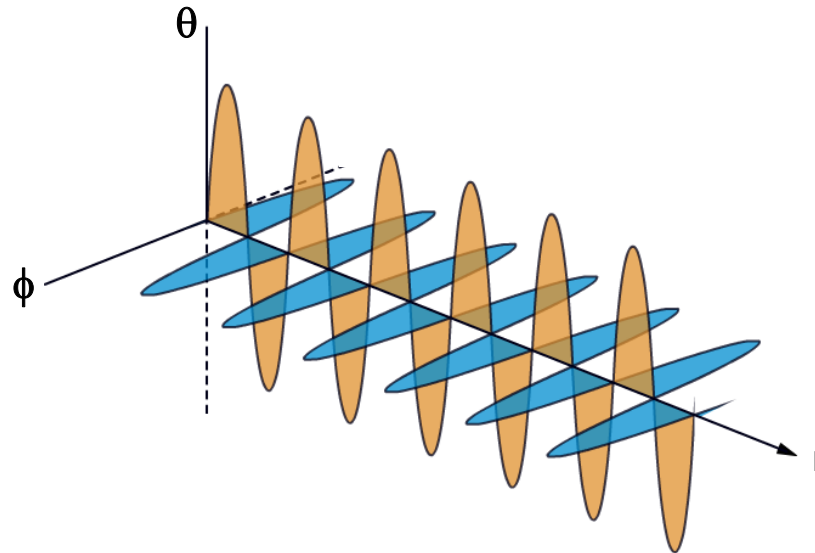



Circular Polarization (CP)



- Electric field components are equal in amplitude, separated in phase by 90 deg
- “Handed-ness” is defined by observation of electric field along propagation direction
- Used for discrimination, polarization diversity, rain mitigation

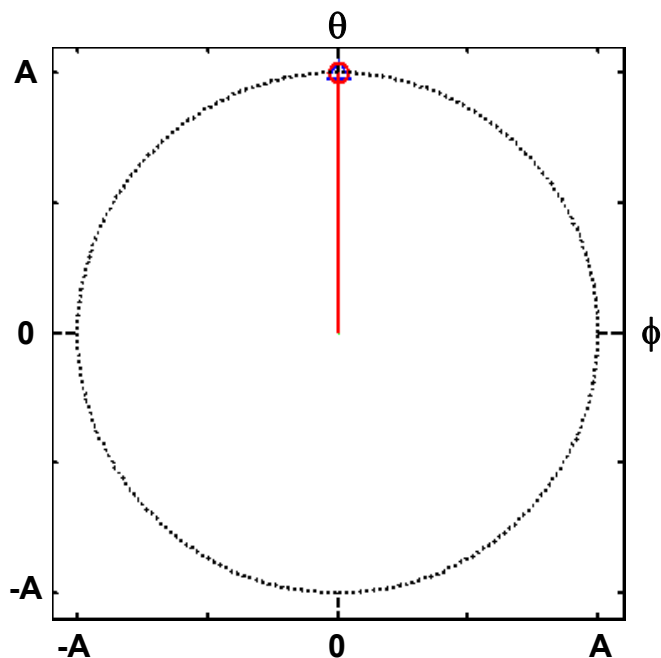

Phasors

$$E_{\theta} = A$$

$$E_{\phi} = Ae^{-j\pi/2}$$

Instantaneous

$$E_{\theta}(t) = A \cos(\omega t)$$

$$E_{\phi}(t) = A \sin(\omega t)$$

**Right-Hand
(RHCP)**

**Left-Hand
(LHCP)**

*Propagation Direction
Into Paper*

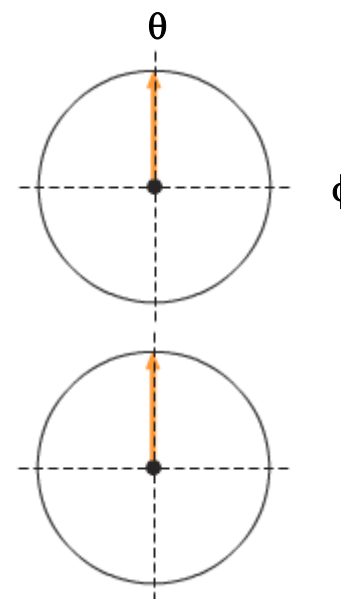

 **Electric Field**

Courtesy of
MIT Lincoln Laboratory
Used with Permission



Propagation – Free Space



- **Plane wave, free space solution to Maxwell's Equations:**

- No Sources

- Vacuum

- Non-conducting medium

$$\vec{\mathbf{E}}(\vec{\mathbf{r}}, t) = \mathbf{E}_0 e^{j(\vec{\mathbf{k}} \cdot \vec{\mathbf{r}} - \omega t)}$$

$$\vec{\mathbf{B}}(\vec{\mathbf{r}}, t) = \mathbf{B}_0 e^{j(\vec{\mathbf{k}} \cdot \vec{\mathbf{r}} - \omega t)}$$

- **Most electromagnetic waves are generated from localized sources and expand into free space as spherical wave.**

- **In the far field, when the distance from the source great, they are well approximated by plane waves when they impinge upon a target and scatter energy back to the radar**



Pointing Vector – Physical Significance



- The **Poynting Vector**, \vec{S} , is defined as:

$$\vec{S} \equiv \vec{E} \times \vec{H}$$

- It is the power density (power per unit area) carried by an electromagnetic wave
- Since both \vec{E} and \vec{H} are functions of time, the **average power density** is of greater interest, and is given by:

$$\langle \vec{S} \rangle = \frac{1}{2} \text{Re} (\vec{E} \times \vec{H}^*) \equiv W_{AV}$$

- For a plane wave in a lossless medium

$$\langle \vec{S} \rangle = \frac{1}{2\eta} |\vec{E}|^2$$

$$\text{where } \eta = \sqrt{\frac{\mu_0}{\epsilon_0}}$$



Modes of Transmission For Electromagnetic Waves



- **Transverse electromagnetic (TEM) mode**
 - Magnetic and electric field vectors are transverse (perpendicular) to the direction of propagation, \hat{k} , and perpendicular to each other
 - Examples (coaxial transmission line and free space transmission,
 - TEM transmission lines have two parallel surfaces

- **Transverse electric (TE) mode**
 - Electric field, \vec{E} , perpendicular to \hat{k}
 - No electric field in \hat{k} direction
- **Transverse magnetic (TM) mode**
 - Magnetic field, \vec{H} , perpendicular to \hat{k}
 - No magnetic field in \hat{k} direction

Used for Rectangular Waveguides

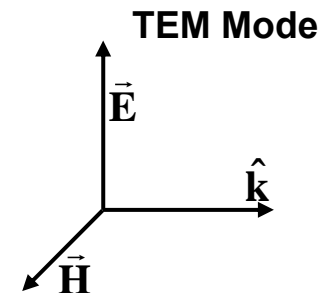

- **Hybrid transmission modes**



Guided Transmission of Microwave Electromagnetic Waves

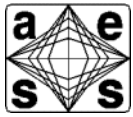

- **Coaxial Cable (TEM mode)**

- Used mostly for lower power and in low frequency portion of microwave portion of spectrum

Smaller cross section of coaxial cable more prone to breakdown in the dielectric

Dielectric losses increase with increased frequency

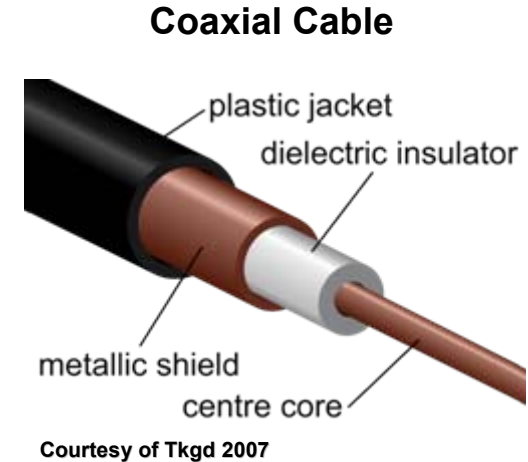

- **Waveguide (TE or TM mode)**

- Metal waveguide used for High power radar transmission

From high power amplifier in transmitter to the antenna feed

- Rectangular waveguide is most prevalent geometry

Rectangular Waveguide

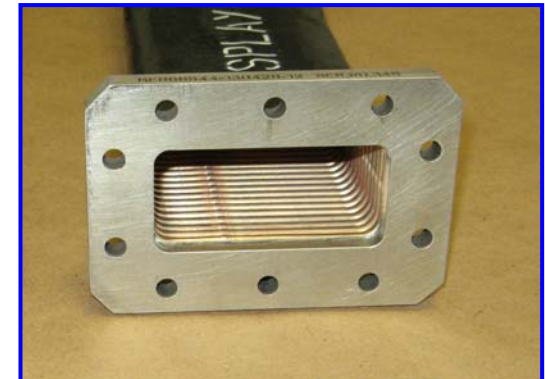

Courtesy of
Cobham Sensor Systems.
Used with permission.



How Is the Size of Radar Targets Characterized ?

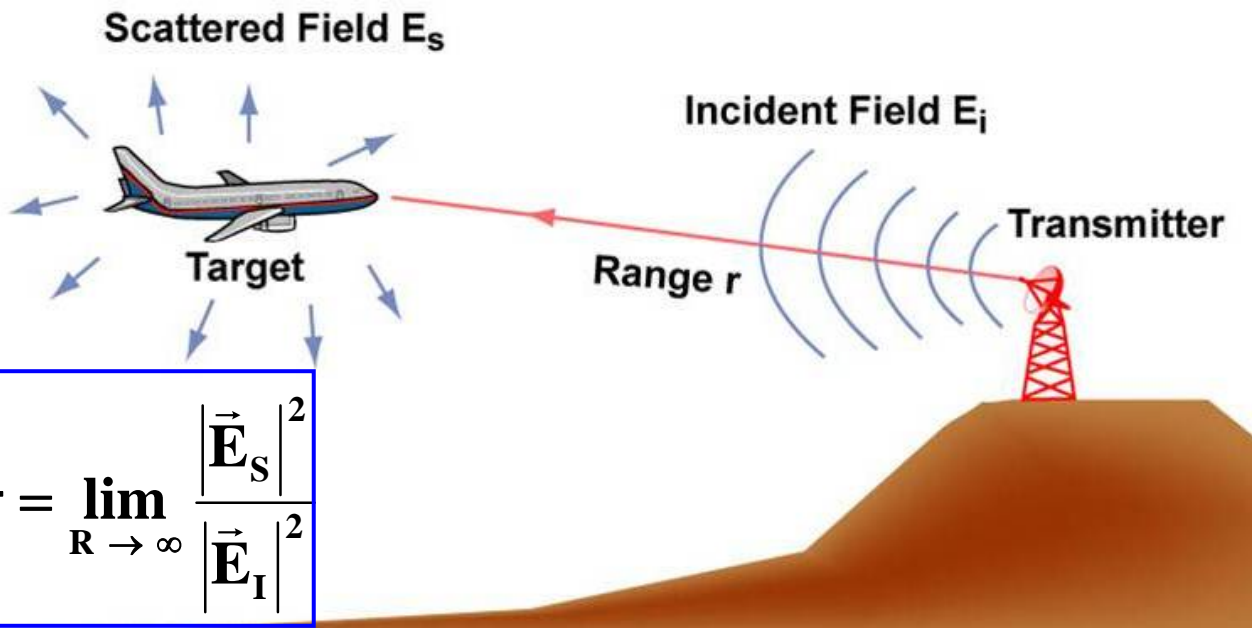

$$\text{Radar Cross Section} = \sigma = \lim_{R \rightarrow \infty} \frac{|\vec{E}_S|^2}{|\vec{E}_I|^2}$$

By MIT OCW

- If the incident electric field that impinges upon a target is known and the scattered electric field is measured, then the “radar cross section” (effective area) of the target may be calculated.



Units- dB vs. Scientific Notation



The relative value of two quantities (in power units), measured on a logarithmic scale, is often expressed in deciBel's (dB)

Example:

$$\text{Signal-to-noise ratio (dB)} = 10 \log_{10} \left[\frac{\text{Signal Power}}{\text{Noise Power}} \right]$$

<u>Factor of:</u>	<u>Scientific Notation</u>	<u>dB</u>	
10	10^1	10	0 dB = factor of 1
100	10^2	20	-10 dB = factor of 1/10
1000	10^3	30	-20 dB = factor of 1/100
⋮			
⋮			
1,000,000	10^6	60	3 dB = factor of 2
			-3 dB = factor of 1/2



Summary



- **This lecture has presented a very brief review of those electromagnetism topics that will be used in this radar course**
- **It is not meant to replace a one term course on advanced undergraduate electromagnetism that physics and electrical engineering students normally take in their 3rd year of undergraduate studies**
- **Viewers of the course may verify (or brush up on) their skills in the area by doing the suggested review problems in Griffith's (see reference 1) and / or Ulaby's (see reference 2) textbooks**



Acknowledgements



- **Prof. Kent Chamberlin, ECE Department, University of New Hampshire**



References



1. Griffiths, D. J., *Introduction to Electrodynamics*, Prentice Hall, New Jersey, 1999
2. Ulaby. F. T., *Fundamentals of Applied Electromagnetics*, Prentice Hall, New Jersey, 5th Ed., 2007
3. Skolnik, M., *Introduction to Radar Systems*, McGraw-Hill, New York, 3rd Ed., 2001
4. Jackson, J. D., *Classical Electrodynamics*, Wiley, New Jersey, 1999
5. Balanis, C. A., *Advanced Engineering Electromagnetics*, Wiley, New Jersey, 1989
6. Pozar, D. M., *Microwave Engineering*, Wiley, New York, 3rd Ed., 2005



Homework Problems



- **Griffiths (Reference 1)**
 - Problems 7-34, 7-35, 7-38, 7-39, 9-9, 9-10, 9-11, 9-33
- **Ulaby (Reference 2)**
 - Problems 7-1, 7-2, 7-10, 7-11, 7-25, 7-26
- **It is important that persons, who view these lectures, be knowledgeable in vector calculus and phasor notation. This next problem will verify that knowledge**
 - **Problem- Take Maxwell's Equations and the continuity equation, in integral form, and, using vector calculus theorems, transform these two sets of equations to the differential form and then transform Maxwell's equations from the differential form to their phasor form.**